

## [Suction filters]

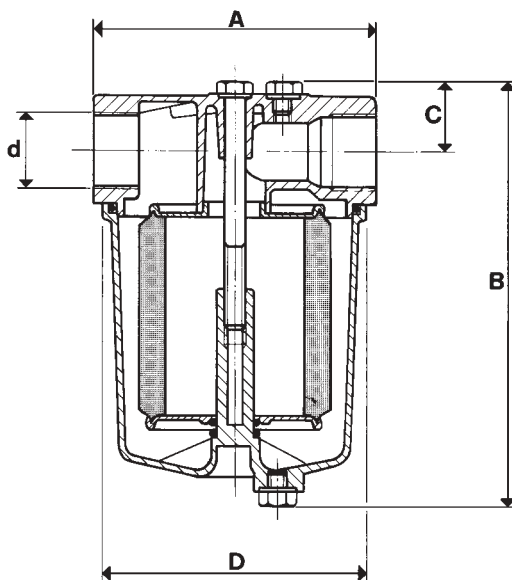

Avoiding impurities reaching the vacuum pump is an essential condition to guarantee its satisfactory operation and long life.

The filters of this series, placed on the suction inlet of the vacuum pumps or on the plants line pipings have this purpose.

Made in a simple and rational way, they have threaded couplings for assembly and an easy opening for a rapid servicing of the filtering cartridge.

Covers are in die-cast aluminium as well as the bowls, except the ones of models FB 5, FB 10 and FB 20 which are in a thermoplastic transparent material.

Filtering cartridges are in stainless steel net with a porosity variable from 44 to 100 micron.

The various models of filters cover a capacity range from 5 to 300 cum/h.

Art.	d Ø	A	B	C	D Ø	Max cap. cum/h
FB 5	1/4"	61	74.5	12.5	59	5
FB 10	3/8"	81	87.0	17.0	79	10
FB 20	1/2"	81	116.0	17.0	79	20
FB 25	3/4"	96	144.0	31.0	90	40
FB 30	1"	120	181.0	31.0	112	70
FB 40	1 1/4"	190	255.0	39.0	182	150
FB 50	1 1/2"	190	255.0	39.0	182	200
FB 60	2"	182	260.0	42.0	182	300

## [Suction filters]



This range of filters has been made in order to permit pumps working also in very dusty environments. When installed on the suction inlet of the pumps, they are able to stop very thin or impalpable powders, interfering on the capacity in an almost negligible way.

Actually, the filtering element is made of special treated paper, with a porosity degree of  $5 \div 7$  micron, pleated to increase the filtering surface and contained in a double case of strong punched plate. The container of the filtering element, as well as the cover, are made in steel plate and painted with a special treatment for avoiding oxidation.

A gasket placed between the cover and the container assures a perfect vacuum seal between the two elements; the release clamps, placed on the container, permit a quick opening of the cover to check or replace the filtering element.

As the filtering element is made of paper, we do not recommend the use of these filters in presence of water or oil vapours or condensates.

At present they are available for capacities from 10 to 680 cum/h.

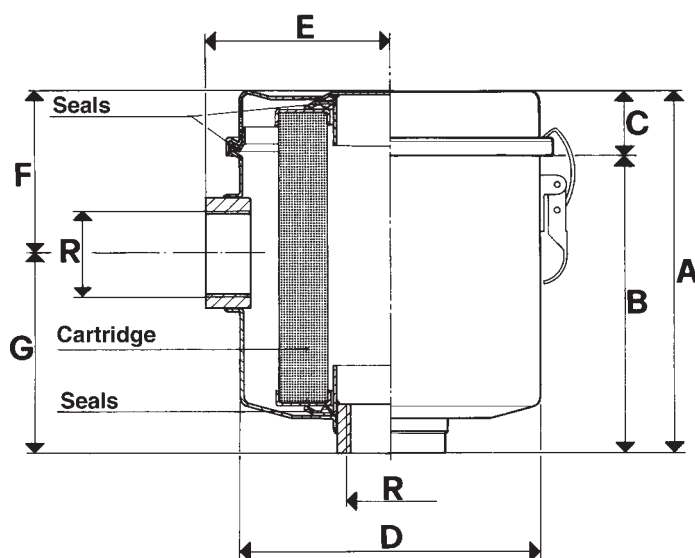

Art.	A	B	C	D	E	F	G	R	Max cap. cum/h
			Ø					Ø	
FC 10	79	70	9	72	49	37	42	3/8"	10
FC 20	93	80	13	96	67	51	42	1/2"	20
FC 25	93	80	13	96	67	51	42	3/4"	40
FC 30	105	91	14	120	82	44	61	1"	70
FC 35	96	81	15	120	82	44	52	1 1/4"	100
FC 40	161	125	36	162	102	77	84	1 1/4"	150
FC 50	197	161	36	160	100	85	112	1 1/2"	200
FC 60	258	235	23	185	115	126	132	2"	300
FC 80	270	246	24	185	125	126	144	3"	680



## [Oil-bath suction filters]

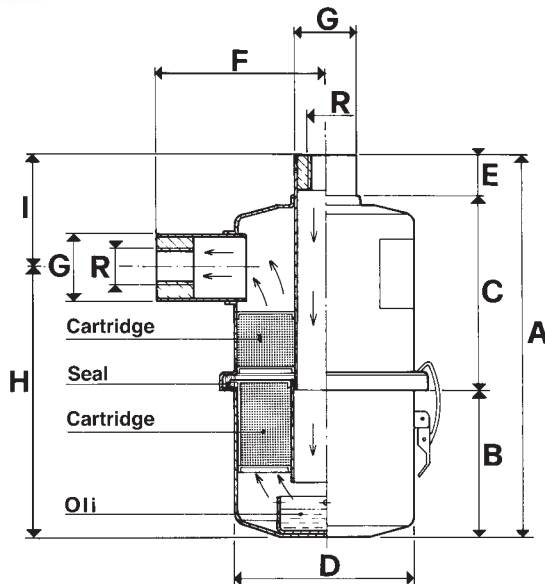

Art.	A	B	C	D	E	F	G	H	I	R	Max cap. cum/h
				Ø			Ø			Ø	
FO 20	216	73	113	105	30	100	40	152	64	1/2"	20
FO 30	239	92	105	132	42	105	50	167	72	1"	70
FO 50	305	110	135	160	60	128	60	205	100	1 1/2"	200
FO 60	340	140	140	185	60	142	67	226	114	2"	300

In applications which experience very thin or impalpable powders, the traditional suction filter would require a cartridge having so thick meshes which, besides decreasing its autonomy, would also considerably reduce the suction capacity of the vacuum pump.

Oil-bath suction filters have been studied in order to overcome this problem.

The main feature of these filters is the ability to retain the smallest and most impalpable dust particles, without reducing the suction capacity of the pump.

They consist of a head and a container in steel plate, coupled with an interposed seal and clamped by release clamps.

Inside the filter, besides the oil bowl, there are two filtering cartridges, one of which is detachable and washable and the other one is fixed; rapidity in access for servicing is guaranteed by the release clamps.

For these filters it is possible to use any kind of oil, also run-down, provided that it still has a minimum viscosity degree.

At present they are available for capacities up to 300 cum/h.

# [Long operation autonomy oil-bath suction filters]



In applications which experience very thin or impalpable powders, the traditional suction filter would require a cartridge having so thick meshes which, besides decreasing its autonomy, would also considerably reduce the suction capacity of the vacuum pump.

Oil-bath suction filters have been studied in order to overcome this problem.

Besides having a long operation autonomy, the main feature of these filters is the ability to retain the thinnest and most impalpable dust, without reducing the suction capacity of the pump.

They are made by a head and a container in steel plate, coupled with an interposed seal and clamped by release clamps.

Inside the filter, besides the oil bowl, there are two filtering cartridges, which are detachable and washable; rapidity in access for servicing is guaranteed by the release clamps.

The oil level and its clogging can be checked by means of two oil windows.

For these filters it is possible to use any kind of oil, also run-down, provided that it still has a minimum viscosity degree.

At the moment they are available for capacities of 200 and 300 cum/h.

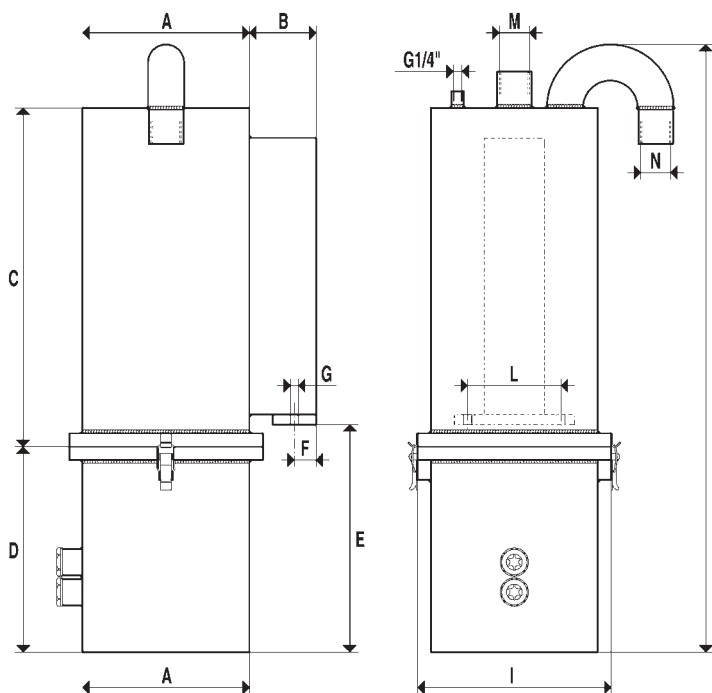

Art.	A Ø	B	C	D	E	F	G Ø	H	I Ø	L	M Ø	N Ø	Max cap. cum/h
<b>F0160</b>	250	100	508	308	356	32.5	12	910	290	140	1 1/2"	1 1/2"	200
<b>F0300</b>	350	80	508	308	356	32.5	12	920	390	200	2"	2"	300



## [ Syphon filters ]

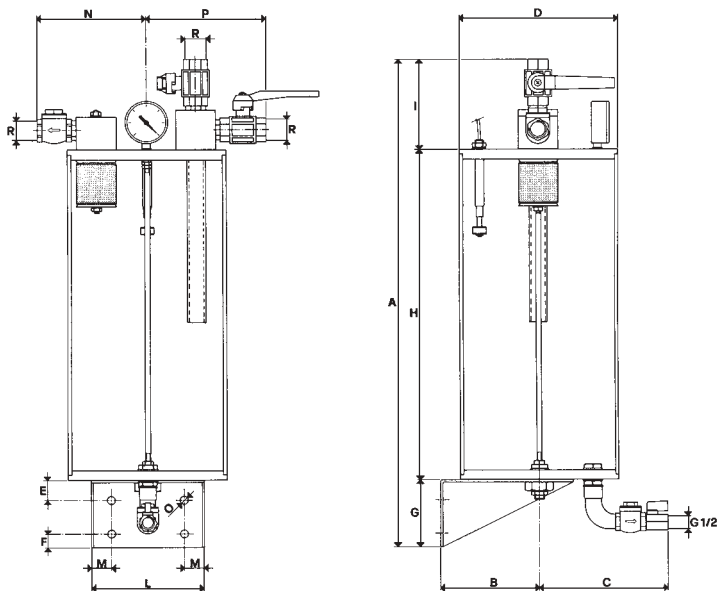

The function of these filters is to retain impurities and liquids extracted through the cups or the vacuum operated stirrup systems, in order to avoid that they enter into the vacuum pumps.

They consist of:

- A cylindrical container in transparent plexiglass, with extractable cover to allow inspection and cleaning.
- A check valve placed on the suction inlet, to prevent the air re-entry into the filter, when the pump stands still.
- A filtering cartridge in stainless steel net with a porosity of 44 micron, placed on the suction inlet, to retain dust and solid impurities.
- A two-way hand operated valve for vacuum interception of the application.
- A two-way hand operated valve for restoring the atmospheric pressure inside the filter.
- A vacuum gauge for the direct reading of the vacuum degree.
- A magnetic level switch with the function to stop the pump when the sucked liquid exceeds the safety level.
- A rigid pipe, connected to the application port, to convey the air flow and the sucked liquid to the bottom of the container.
- A check valve placed on the bottom of the filter, to drain automatically the sucked liquids and impurities, every time that the atmospheric pressure is restored inside the filter.
- A chock, applied on the above described check valve, which allows the manual drainage of the liquids.
- A strong metal bracket to allow mounting of the unit on a wall.

At present they are available for capacities up to 70 cum/h.

Art.	A	B	C	D	E	F	G	H	I	L	M	N	O	P	R	Max Cap cum/h	Contents lt.
				Ø									Ø	Ø			
FS 20	620	130	175	200	25	20	100	400	120	150	25	140	10	145	1/2"	20	10.5
FS 25	740	150	195	240	25	20	100	500	140	170	30	170	11	180	3/4"	40	19.5
FS 30	880	190	225	300	30	20	120	600	160	200	40	205	11	220	1"	70	38.0

## [ Suction filters for pneumatic suction and blowing pumps ]

These filters have been developed in order to permit pneumatic suction and blowing pumps working also in very dusty environments. When installed on their suction connections, they are able to stop very thin powders, interfering on the flow capacity in an almost negligible way.

Actually, the filtering element is made with a special treated paper, with a porosity degree of  $5\div 7$  micron, pleated to increase the filtering surface.

The FP filter bowl is made of a transparent plastic and it is screwed to the head, also made of plastic; a gasket placed between the two elements, assures a perfect seal.

The head and bowl of the FC filter are manufactured from steel plate with a special painted surface to prevent oxidization.

A gasket placed between the head and bowl assures a perfect vacuum seal and the release clamps, placed on the bowl, allow a quick opening of the head to check or replace the filtering element.

Art.	d Ø	A	B	C	D Ø	Max cap. cum/h	For pumps
FP 25	3/4"	145	169	26	130	70	---
FP 30	1"	145	169	26	130	100	PA-PS40÷100
FC 38	1 1/2"	143	105	44	120	200	PA-PS140÷200
FC 55	2"	143	170	80	120	300	PA-PS250÷300

